

**Operating Instructions
Bedienungsanleitung
Instructions d'utilisation
Istruzioni per l'uso
Gebruiksaanwijzing
Manual de instrucciones
Brugsvejledning
Driftsföreskrifter
Bruksanvisning
Käyttöohjeet**

Panasonic

**Cordless Drill & Driver/Cordless Hammer Drill & Driver
Akku-Bohrschrauber/Akku-Schlagbohrschrauber
Perceuse-visseuse sans fil/Perceuse à percussion-visseuse sans fil
Trapano avvitatore cordless/Trapano avvitatore cordless a percussione
Snoerloze schroef-boormachine/Snoerloze slagschroef-boormachine
Destornillador y taladro sin cables/Destornillador y taladro percutor sin cables
Akku bor & skruetrækker/Akku hammerbor & skruetrækker
Sladdlös skruvdragare & bormaskin/slagbormaskin
Ledningløs drill og skrutrekker/Ledningløs slagdrill og skrutrekker
Ladattava pora & ruuvinväännin/ladattava vasaraporapora & ruuvinväännin**

Model No: EY7442/EY7450/EY7950

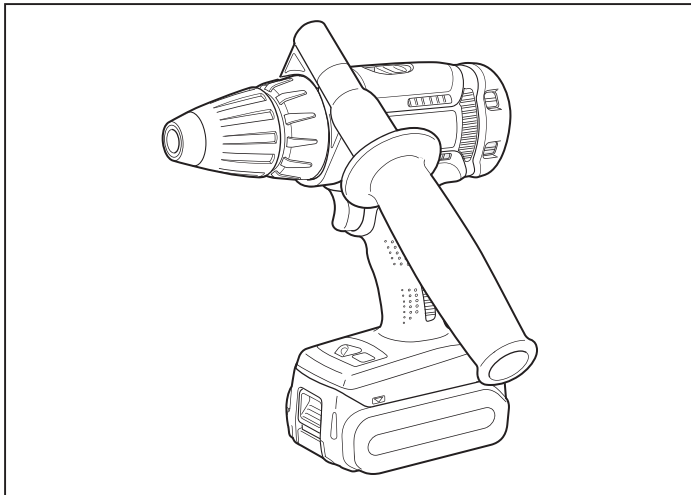

Before operating this unit, please read these instructions completely and save this manual for future use.

Vor Inbetriebnahme des Gerätes die Betriebsanleitung bitte gründlich durchlesen und diese Broschüre zum späteren Nachschlagen sorgfältig aufbewahren.

Lire entièrement les instructions suivantes avant de faire fonctionner l'appareil et conserver ce mode d'emploi à des fins de consultation ultérieure.

Prima di usare questa unità, leggere completamente queste istruzioni e conservare il manuale per usi futuri.

Lees deze gebruiksaanwijzing aandachtig door voor u het apparaat in gebruik neemt en bewaar de gebruiksaanwijzing voor eventuele naslag.

Antes de usar este aparato por primera vez, lea todas las instrucciones de este manual y guarde el manual para poderlo consultar en el futuro.

Gennemlæs denne betjeningsvejledning før brugen og gem den til fremtidig brug.

Läs igenom hela bruksanvisningen innan verktyget tas i bruk. Spara bruksanvisningen för senare användning.

Før enheten tas i bruk, vennligst les disse alle anvisningene og oppbevar deretter bruksanvisningen for senere bruk.

Lue ohjeet huolella ennen laitteen käyttöönottoa ja säilytä tämä käyttöohje tallessa tulevaa tarvetta varten.

Original instructions: English
Translation of the original instructions:
Other languages

Read “the Safety Instructions” booklet
and the following before using.

I. INTENDED USE







These tools can be used to tighten screws in clutch mode and to drill holes in wood and metal in drill mode. Additionally, model EY7950 can be used to drill holes in soft concrete and similar materials in hammer mode.

Read the Safety Instructions booklet
and the following before using.

II. ADDITIONAL SAFETY RULES

- 1) **Wear ear protectors.**
Exposure to noise can cause hearing loss.
- 2) **Use auxiliary handle supplied with the tool.**
Loss of control can cause personal injury.
- 3) **Hold power tools by insulated gripping surfaces when performing an operation where the cutting tool may contact hidden wiring;** contact with a “live” wire will make exposed metal parts of the tool “live” and shock the operator.
- 4) Wear a dust mask, if the work causes dust.
- 5) Be aware that this tool is always in an operating condition, since it does not have to be plugged into an electrical outlet.
- 6) When drilling or driving into walls, floors, etc., “live” electrical wires may be encountered. **DO NOT TOUCH THE CHUCK OR ANY FRONT METAL PARTS OF THE TOOL!** Hold the tool only by the plastic handle to prevent electric shock in case you drill or drive into a “live” wire.
- 7) If the bit becomes jammed, immediately turn the trigger switch off to prevent an overload, which can damage the battery pack or motor. Use reverse motion to loosen jammed bits.
- 8) Do NOT operate the Forward/Reverse lever when the trigger switch is on. The battery will discharge rapidly and damage to the unit may occur.
- 9) During charging, the charger may become slightly warm. This is normal. Do NOT charge the battery for a long period.

- 10) When storing or carrying the tool, set the Forward/Reverse lever to the center position (switch lock).
- 11) Do not strain the tool by holding the speed control trigger halfway (speed control mode) so that the motor stops.
- 12) Do not operate the speed selector switch (LOW-HIGH) while pulling on the speed control trigger. This can cause the rechargeable battery to wear quickly or damage the internal mechanism of the motor.

Symbol	Meaning
V	Volts
===	Direct current
n_0	No load speed
... min ⁻¹	Revolutions or reciprocations per minutes
Ah	Electrical capacity of battery pack
	Forward rotation
	Reverse rotation
	Rotation with hammering
	Rotation only
	To reduce the risk of injury, user must read and understand instruction manual.
	For indoor use only.

⚠ WARNING:

- Do not use other than the Panasonic battery packs that are designed for use with this rechargeable tool.
- Panasonic is not responsible for any damage or accident caused by the use of the recycled battery pack and the counterfeit battery pack.
- Do not dispose of the battery pack in a fire, or expose it to excessive heat.
- Do not drive the likes of nails into the battery pack, subject it to shocks, dismantle it, or attempt to modify it.
- Do not allow metal objects to touch the battery pack terminals.
- Do not carry or store the battery pack in the same container as nails or similar metal objects.
- Do not charge the battery pack in a high-temperature location, such as next to a fire or in direct sunlight. Otherwise, the battery may overheat, catch fire, or explode.
- Never use other than the dedicated charger to charge the battery pack. Otherwise, the battery may leak, overheat, or explode.
- After removing the battery pack from the tool or the charger, always reattach the pack cover. Otherwise, the battery contacts could be shorted, leading to a risk of fire.
- When the Battery Pack Has Deteriorated, Replace It with a New One. Continued use of a damaged battery pack may result in heat generation, ignition or battery rupture.

III. ASSEMBLY

Attaching or Removing Bit

NOTE:

When attaching or removing a bit, disconnect battery pack from tool or place the switch in the center position (switch lock).

This tool is equipped with a keyless drill chuck.

1. Attachment

Insert the bit and turn the lock collar clockwise (looking from the front) to tighten firmly until it stops clicking.

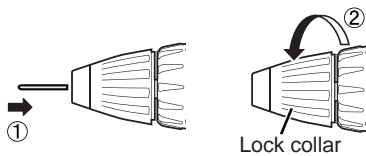

2. Removal

Turn the lock collar counterclockwise (looking from the front), then remove the bit.



NOTE:

If excessive play occurs in the chuck, secure the drill in place and ① open the chuck jaws by turning the lock collar and ② tighten the screw (left-handed screw) with a screwdriver by turning it counterclockwise (viewed from the front).

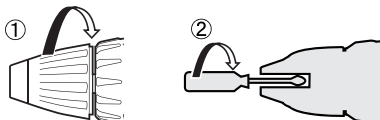

Attaching or Removing Battery Pack

1. To connect the battery pack:

Line up the alignment marks and attach the battery pack.

- Slide the battery pack until it locks into position.

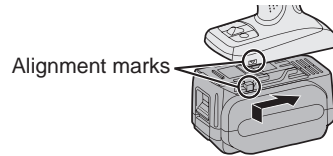

2. To remove the battery pack:

Pull the button from the front to release the battery pack.

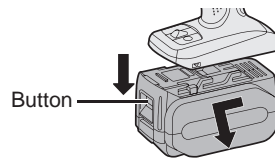

Support handle

Place the support handle at your favorite position and tighten the handle securely.

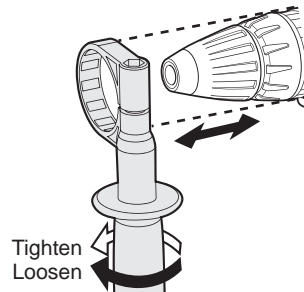

Always use the support handle to ensure operating safety.

IV. OPERATION

[Main Body]

Switch Operation

1. The speed increases with the amount of depression of the trigger. When beginning work, depress the trigger slightly to start the rotation slowly.
2. A feedback electronic controller is used to give a strong torque even in low speed.
3. The brake operates when the trigger is released and the motor stops immediately.

NOTE:

- When the brake operates, a braking sound may be heard. This is normal.
- Sparks from the motor brush may be visible through the body vent holes on the back of the tool during switching and braking due to the load imposed on the motor. This does not indicate a problem with the tool.

CAUTION:

When operating the tool by pulling the trigger, there may be a momentary lag before rotation starts. This does not signal a malfunction.

- * This lag occurs as the tool's circuitry starts up when the trigger is pulled for the first time after installing a new battery pack or after the tool has not been used for at least 1 minute (or at least 5 minutes when the LED is on). Rotation will start without any lag during second and subsequent operations.

Switch and Forward/Reverse Lever Operation

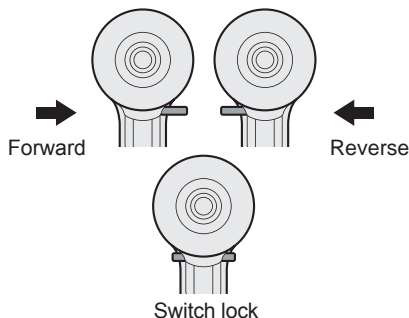

CAUTION:

To prevent damage, do not operate Forward/Reverse lever until the bit comes to a complete stop.

Forward Rotation Switch Operation

1. Push the lever for forward rotation.
2. Depress the trigger switch slightly to start the tool slowly.
3. The speed increases with the amount of depression of the trigger for efficient tightening of screws and drilling. The brake operates and the chuck stops immediately when the trigger is released.
4. After use, set the lever to its center position (switch lock).

Reverse Rotation Switch Operation

1. Push the lever for reverse rotation. Check the direction of rotation before use.
2. Depress the trigger switch slightly to start the tool slowly.
3. After use, set the lever to its center position (switch lock).

Clutch Torque Setting

Adjust the torque to one of the 18 clutch settings or “” position (EY7442, EY7450).

Adjust the torque to one of the 18 clutch settings or “”, “” position (EY7950).

NOTE:

Always make sure to stop operation of the tool and disengage it from the work, when you select Hammering mode from Drilling mode or when you shift to Drilling mode from Hammering mode by rotating clutch handle.

CAUTION:

Set the clutch setting at this mark (◁) before actual operation.

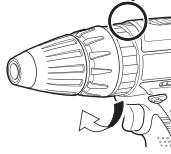

If the clutch handle cannot be set at “drilling” or “hammering” mode after drilling with clutch function, set the clutch handle at position 1 and operate the clutch for a second.

Speed Selection

Choose a low or high speed to suit the use.



The more the variable speed control trigger is pulled, the higher the speed becomes.

WARNING:

- Do not inhale any smoke emitted from the tool or battery pack as it may be harmful.

CAUTION:

- Check the speed selector switch before use.
- Use at low speed when high torque is needed during operation. (Using at high speed when high torque is required may cause a motor breakdown.)
- Do not use the tool in a manner that causes the motor to lock up. Doing so may damage the tool and battery pack, resulting in smoke or fire.
- Do not operate the speed selector switch (LOW-HIGH) while pulling on the speed control trigger. This can cause the rechargeable battery to wear quickly or damage the internal mechanism of the motor.

* See specifications for “MAXIMUM RECOMMENDED CAPACITIES”.

CAUTION:

- To prevent excessive temperature increase of the tool surface, do not operate the tool continuously using two or more battery packs. The tool needs cool-off time before switching to another pack.
- Do not close up vent holes on the sides of the body during operation. Otherwise, the machine function is adversely affected to cause a failure.
- Do NOT strain the tool (motor). This may cause damage to the unit.
- Use the tool in such a way as to prevent the air from the body vent holes from blowing directly onto your skin. Otherwise, you may get burned.

Bit-locking Function

1. With the trigger switch not engaged and a screwdriver bit locked in place, the tool can be used as a manual screwdriver.
(EY7442: up to 36 N·m, 367kgf-cm, 319 in-lbs)
(EY7450, 7950: up to 40 N·m, 408kgf-cm, 353 in-lbs)
There will be a little play in the chuck, but this is not a malfunction.
2. This feature is handy for tightening screws that require more torque than the maximum torque of the driver (position 2 on the clutch), for confirming the tightness of a screw or to loosen an extremely tight screw.

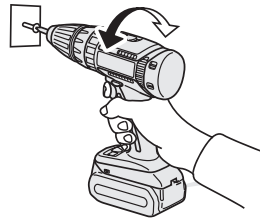

Control Panel

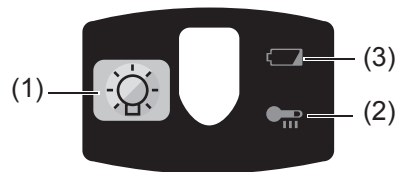

(1) LED light

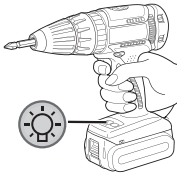

Before the use of LED light, always pull the power switch once.

Press  the LED light button.

The light illuminates with very low current, and it does not adversely affect the performance of the tool during use or its battery capacity.

CAUTION:

- **The built-in LED light is designed to illuminate the small work area temporarily.**
- **Do not use it as a substitute for a regular flashlight, since it does not have enough brightness.**
- **LED light turns off when the tool has not been used for 5 minutes.**

Caution: DO NOT STARE INTO BEAM.
Use of controls or adjustments or performance of procedures other than those specified herein may result in hazardous radiation exposure.

(2) Overheat warning lamp

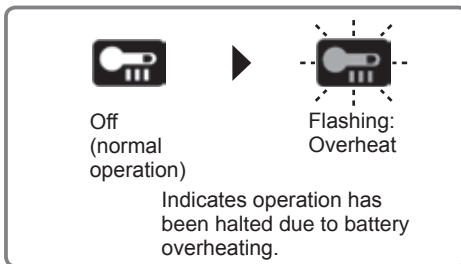

To protect the motor or battery, be sure to note the following when carrying out this operation.

- If the motor or battery becomes hot, the protection function will be activated and the motor or battery will stop operating. The overheat warning lamp on the control panel illuminates or flashes when this feature is active.
- If the overheating protection feature activates, allow the tool to cool thoroughly (at least 30 minutes). The tool is ready for use when the overheat warning lamp goes out.

- Avoid using the tool in a way that causes the overheating protection feature to activate repeatedly.
- If the tool is operated continuously under high-load conditions or if it is used in hot-temperature conditions (such as during summer), the overheating protection feature may activate frequently.
- If the tool is used in cold-temperature conditions (such as during winter) or if it is frequently stopped during use, the overheating protection feature may not activate.
- The performance of the EY9L42 deteriorates significantly at and below 10°C due to work conditions and other factors.
- The ambient temperature range is between 0°C (32°F) and 40°C (104°F). If the battery pack is used when the battery temperature is below 0°C (32°F), the tool may fail to function properly.
- When charging a cool battery pack (below 0°C (32°F)) in a warm place, leave the battery pack at the place and wait for more than one hour to warm up the battery to the level of the ambient temperature.

(3) Battery low warning lamp

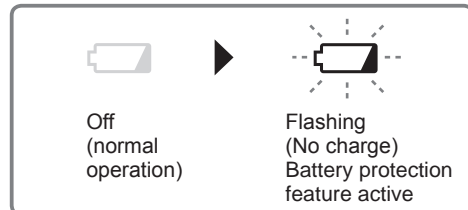

Excessive (complete) discharging of lithium ion batteries shortens their service life dramatically. The driver includes a battery protection feature designed to prevent excessive discharging of the battery pack.

- The battery protection feature activates immediately before the battery loses its charge, causing the battery low warning lamp to flash.
- If you notice the battery low warning lamp flashing, charge the battery pack immediately.

- If it is started with too little battery power remaining, the tool may stop operating without the battery low warning lamp flashing first. This indicates that there is too little battery power remaining to use the tool, and the battery pack should be charged before further use.
- If the tool is subject to a sudden load during use that causes the motor to lock up, the overdischarge prevention sensor may be triggered, and the battery low warning lamp may flash. The lamp will stop flashing once you address the cause of the motor's locking up and cycle the trigger.

[Battery Pack] For Appropriate Use of Battery pack

Li-ion Battery pack

- For optimum battery life, store the Li-ion battery pack following use without charging it.
- When charging the battery pack, confirm that the terminals on the battery charger are free of foreign substances such as dust and water etc. Clean the terminals before charging the battery pack if any foreign substances are found on the terminals.
The life of the battery pack terminals may be affected by foreign substances such as dust and water etc. during operation.
- When battery pack is not in use, keep it away from other metal objects like: paper clips, coins, keys, nails, screws, or other small metal objects that can make a connection from one terminal to another.
Shorting the battery terminals together may cause sparks, burns or a fire.
- When operating the battery pack, make sure the work place is well ventilated.

- When the battery pack is removed from the main body of the tool, replace the battery pack cover immediately in order to prevent dust or dirt from contaminating the battery terminals and causing a short circuit.

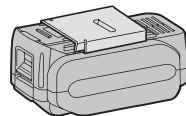

Battery Pack Life

The rechargeable batteries have a limited life. If the operation time becomes extremely short after recharging, replace the battery pack with a new one.

Battery Recycling

ATTENTION:

For environmental protection and recycling of materials, be sure that it is disposed of at an officially assigned location, if there is one in your country.

[Battery Charger]

Charging

Cautions

- If the temperature of the battery pack falls approximately below -10°C (14°F), charging will automatically stop to prevent degradation of the battery.
- The ambient temperature range is between 0°C (32°F) and 40°C (104°F).
If the battery pack is used when the battery temperature is below 0°C (32°F), the tool may fail to function properly.
- When charging a cool battery pack (below 0°C (32°F)) in a warm place, leave the battery pack at the place and wait for more than one hour to warm up the battery to the level of the ambient temperature.

- Cool down the charger when charging more than two battery packs consecutively.
- Do not insert your fingers into contact hole, when holding charger or any other occasions.

To prevent the risk of fire or damage to the battery charger.

- Do not use power source from an engine generator.
- Do not cover vent holes on the charger and the battery pack.
- Unplug the charger when not in use.

Li-ion Battery Pack

NOTE:

Your battery pack is not fully charged at the time of purchase. Be sure to charge the battery before use.

Battery charger

1. Plug the charger into the AC outlet.
2. Insert the battery pack firmly into the charger.

1. Line up the alignment marks and place the battery onto the dock on the charger.
2. Slide forward in the direction of the arrow.

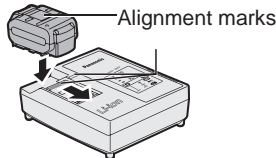

3. During charging, the charging lamp will be lit.

When charging is completed, an internal electronic switch will automatically be triggered to prevent overcharging.

- Charging will not start if the battery pack is warm (for example, immediately after heavy-duty operation). The orange standby lamp will be flashing until the battery cools down. Charging will then begin automatically.

4. The charge lamp (green) will flash slowly once the battery is approximately 80% charged.
5. When charging is completed, the charging lamp in green color will turn off.
6. If the temperature of the battery pack is 0°C or less, charging takes longer to fully charge the battery pack than the standard charging time. Even when the battery is fully charged, it will have approximately 50% of the power of a fully charged battery at normal operating temperature.
7. Consult an authorized dealer if the charging lamp (green) does not turn off.
8. If a fully charged battery pack is inserted into the charger again, the charging lamp lights up. After several minutes, the charging lamp in green color will turn off.
9. Remove the battery pack while the battery pack release button is held up.

Battery pack release button

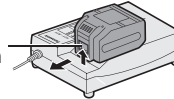

LAMP INDICATIONS

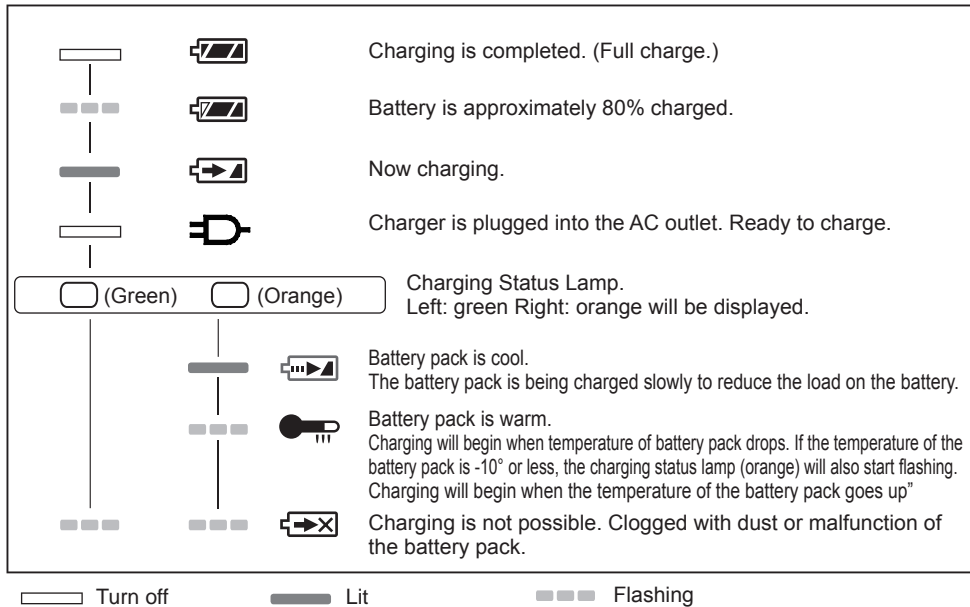

Information for Users on Collection and Disposal of Old Equipment and used Batteries



These symbols on the products, packaging, and/or accompanying documents mean that used electrical and electronic products and batteries should not be mixed with general household waste.

For proper treatment, recovery and recycling of old products and used batteries, please take them to applicable collection points, in accordance with your national legislation and the Directives 2002/96/EC and 2006/66/EC.



By disposing of these products and batteries correctly, you will help to save valuable resources and prevent any potential negative effects on human health and the environment which could otherwise arise from inappropriate waste handling.

For more information about collection and recycling of old products and batteries, please contact your local municipality, your waste disposal service or the point of sale where you purchased the items. Penalties may be applicable for incorrect disposal of this waste, in accordance with national legislation.

For business users in the European Union

If you wish to discard electrical and electronic equipment, please contact your dealer or supplier for further information.

[Information on Disposal in other Countries outside the European Union]

These symbols are only valid in the European Union. If you wish to discard these items, please contact your local authorities or dealer and ask for the correct method of disposal.

Note for the battery symbol (bottom two symbol examples):

This symbol might be used in combination with a chemical symbol. In this case it complies with the requirement set by the Directive for the chemical involved.

V. MAINTENANCE

- Use only a dry, soft cloth for wiping the unit. Do not use a damp cloth, thinner, benzene, or other volatile solvents for cleaning.
- In the event that the inside of the tool or battery pack is exposed to water, drain and allow to dry as soon as possible. Carefully remove any dust or iron filings that collect inside the tool. If you experience any problems operating the tool, consult with a repair shop.

VI. ACCESSORIES

Use only bits suitable for size of drill's chuck.

VII. APPENDIX

MAXIMUM RECOMMENDED CAPACITIES

	Model	EY7442	EY7450	EY7950
Screw driving	Machine screw	M8		
	Wood screw	ø 10 mm or ø 6,8 mm		
Drilling	Self-drilling screw	ø 6 mm		
	For Wood	ø 36 mm		
	For Metal	ø 13 mm		
	For Masonry	ø 13 mm		

VIII. SPECIFICATIONS

MAIN UNIT

Model		EY7442	EY7450	EY7950
Motor voltage		14.4 V	18 V	
No load speed	Low	0 – 410 min ⁻¹	0 – 430 min ⁻¹	
	High	0 – 1530 min ⁻¹	0 – 1650 min ⁻¹	
Blows Rate Per Minute	Low	---		1800 – 7740 min ⁻¹
	High	---		6840 – 29700 min ⁻¹
Chuck capacity		ø 1.5 mm – ø 13 mm		
Clutch torque		Approx 1.0 N·m – 6.9 N·m		
Overall length		218 mm	218 mm	235 mm
Weight (with battery pack)		2.05 kg	2.15 kg	2.3 kg
Noise vibration		See in the included sheet		

BATTERY PACK

Model No.	EY9L41	EY9L42	EY9L44	EY9L45	EY9L50	EY9L51
Storage battery	Li-ion Battery					
Motor voltage	14.4V DC (3.6 V × 4 cells)		14.4V DC (3.6 V × 8 cells)		18V DC (3.6 V × 10 cells)	

BATTERY CHARGER

Model No.	EY0L81					
Electrical rating	See the rating plate on the bottom of the charger					
Weight	0.93 kg					
Charging time	EY9L41	EY9L42	EY9L44	EY9L45	EY9L50	EY9L51
	Usable: 45min	Usable: 30min	Usable: 50min	Usable: 65min	Usable: 50min	Usable: 65min
	Full:60min	Full:35min	Full:65min	Full:80min	Full:65min	Full:80min
Model No.	EY0L82					
Electrical rating	See the rating plate on the bottom of the charger					
Weight	0.93 kg					
Charging time	EY9L41	EY9L42	EY9L44	EY9L45	EY9L50	EY9L51
	Usable: 35min	Usable: 30min	Usable: 40min	Usable: 50min	Usable: 40min	Usable: 55min
	Full:50min	Full:35min	Full:55min	Full:60min	Full:55min	Full:70min

NOTE: This chart may include models that are not available in your area.

Please refer to the latest general catalogue.

NOTE: For the dealer name and address, please see the included warranty card.

ONLY FOR U. K.



IX. ELECTRICAL PLUG INFORMATION

FOR YOUR SAFETY PLEASE READ THE FOLLOWING TEXT CAREFULLY

This appliance is supplied with a moulded three pin mains plug for your safety and convenience.

A 5 amp fuse is fitted in this plug.

Should the fuse need to be replaced please ensure that the replacement fuse has a rating of 5 amp and that it is approved by ASTA or BSI to BS1362.

Check for the ASTA mark  or the BSI mark  on the body of the fuse.

If the plug contains a removable fuse cover you must ensure that it is refitted when the fuse is replaced.

If you lose the fuse cover the plug must not be used until a replacement cover is obtained.

A replacement fuse cover can be purchased from your local Panasonic Dealer.

IF THE FITTED MOULDED PLUG IS UNSUITABLE FOR THE SOCKET OUTLET IN YOUR HOME THEN THE FUSE SHOULD BE REMOVED AND THE PLUG CUT OFF AND DISPOSED OF SAFELY.

THERE IS A DANGER OF SEVERE ELECTRICAL SHOCK IF THE CUT OFF PLUG IS INSERTED INTO ANY 13 AMP SOCKET.

If a new plug is to be fitted please observe the wiring code as shown below.

If in any doubt please consult a qualified electrician.

IMPORTANT:

The wires in this mains lead are coloured in accordance with the following code:

Blue: Neutral

Brown: Live

As the colours of the wire in the mains lead of this appliance may not correspond with the coloured markings identifying the terminals in your plug, proceed as follows.

The wire which is coloured BLUE must be connected to the terminal in the plug which is marked with the letter N or coloured BLACK. The wire which is coloured BROWN must be connected to the terminal in the plug which is marked with the letter L or coloured RED. Under no circumstances should either of these wires be connected to the earth terminal of the three pin plug, marked with the letter E or the Earth Symbol .

How to replace the fuse: Open the fuse compartment with a screwdriver and replace the fuse and fuse cover if it is removable.

